

TEJO

Serve-over Counters
Vitrines Exposition

FRILIXA
display solutions



Pastry
Pâtisserie





Pastry
Pâtisserie

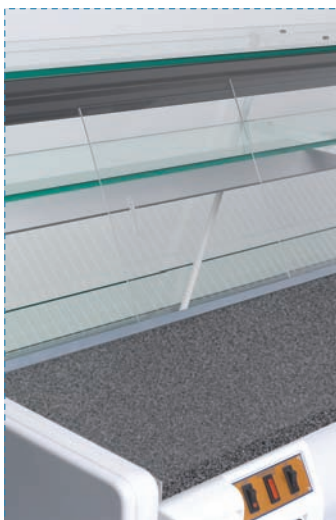

Sliding doors
Portes coulissantes



Drawer
Tiroir



Control panel
Tableau de contrôle

CHARACTERISTICS CARACTÉRISTIQUES

- › Refrigeration system utilizes natural air circulation;
 - › Electronically controlled with digital temperature display;
 - › 10 amp socket for slicer / scales...;
 - › Three intermediate ambient shelves as standard;
 - › Slide out rear decks for ease loading/cleaning;
 - › Marble rear shelf;
 - › Insulation by injected polyurethane "In Situ" - 100% CFC free;
 - › Internal illumination for better display;
 - › Temperature range: +2°C / +8°C;
 - › Refrigerant R134a.
- › Réfrigération par le système de circulation naturelle d'air;
 - › Microprocesseur électronique programmable avec indication de température;
 - › Prise supplémentaire de 10 ampères;
 - › Modèle standard comprend trois étagères;
 - › Tiroirs en inox pour un chargement plus facile;
 - › Plan de travail en marbre;
 - › Isolation au polyuréthane - sans CFC;
 - › Eclairage intérieur pour une meilleure présentation des produits;
 - › Gamme de température: +2°C / +8°C;
 - › Réfrigérant R134a.

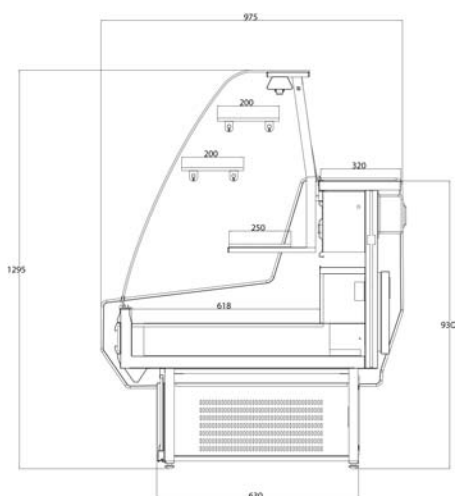

TECHNICAL DATA DONNÉES TECHNIQUES

| | 1,00 m | 1,50 m | 2,00 m | 3,00 m |
|---|--------|--------|--------|--------|
| Length (m) Longueur (m) | 1,100 | 1,450 | 2,100 | 2,750 |
| Display area (m2) Surface d'exposition (m2) | - | 1,046 | 1,550 | 2,054 |
| Number of drawers Nombre de tiroirs | 1 | 2 | 3 | 4 |
| Package volume (m3) Volume avec emballage (m3) | 1,600 | 2,060 | 2,910 | 3,770 |
| Net weight (kg) Poids net (kg) | 176 | 214 | 306 | 396 |
| Gross weight (kg) Poids brut (kg) | 230 | 264 | 336 | 474 |

TEJO

Serve-over Counters
Vitrines Exposition

FRILIXA
display solutions